



Conductively Cooled Laser Bar Stack

M-Stack λ 780-830nm

Features:

- Improved cooling efficiency
- No “smile” effect
- Bars on demand
- Central wavelength on demand

Suitable for:

- Hair Removal
- Material processing
- Printing
- Defense
- Industry

M-Stack λ 780-830nm

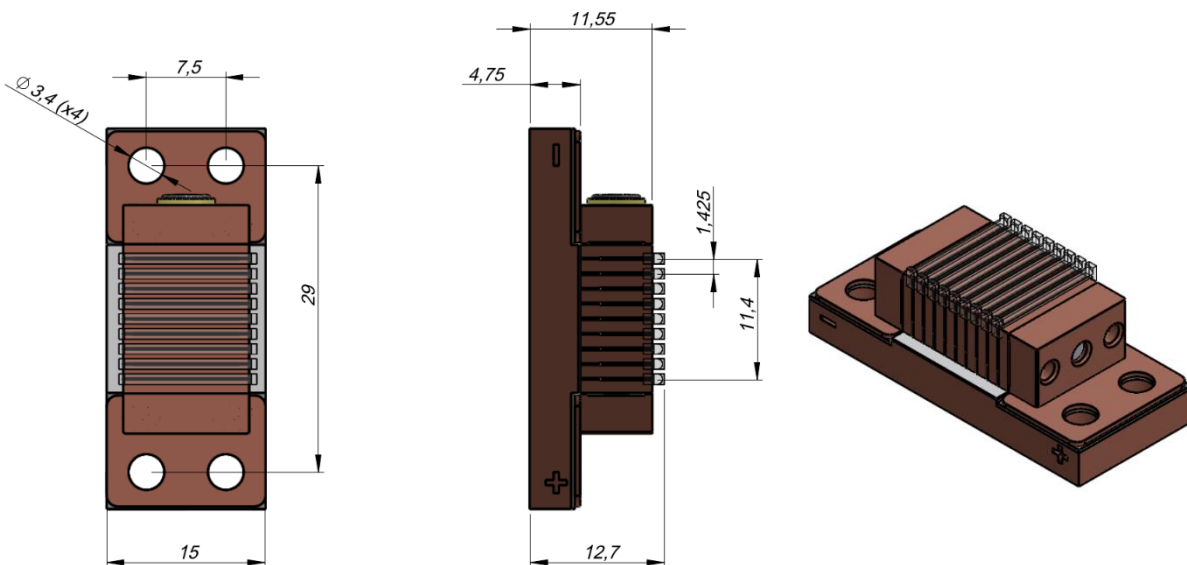

M-STACK / 780- 830nm

Product specification are subject to change without notice.
For complete details, please contact your local MONOCROM sales representative.

MONOCROM S.L.

C/Vilanoveta 6
08800 Vilanova i la Geltrú (Barcelona)
Spain
T. +34 938 149 450
F. +34 938 143 767
E. sales@monocrom.com
www.monocrom.com

M-Stack λ 780-830nm | TECH Specifications

Laser Parameters^(1,2,3)

Type	actively cooled stack
Wavelength ⁽¹⁾ [nm]	780 - 830
Wavelength tolerance [nm]	± 20
Spectral width [nm]	3
Wavelength shift [nm/K]	0.27
Output power ^(2,3) [W]	CW - up to 100 / QCW - up to 500
Operating current [A]	CW < 120 / QCW < 480
Efficiency coefficient [W/A]	1.2
Voltage @ connectors ⁽⁴⁾ [V]	2 - 30
Bar to bar pitch [mm]	down to 0.4
Optics (optional)	FAC / SAC / BT
Laser bars per stack ⁽⁵⁾	1 - 15
Smile [μ m]	< 0.3

1. Other wavelengths on request.
2. Specification are subjected to chips availability.
3. Expected output power per laser bar. Can varies based on current and temperature.
4. Voltage from the power supply must be higher, as due to high current there will be a voltage drop in the cables.
5. Pitch dependent

No mechanical stress

Our patented solder-free technology is used in our diode bars stacks. Thanks to it clamped bars expand and contract freely during the thermal cycles of the pulsed regime avoiding mechanical stress.



M-STACK / 780- 830nm

Product specification are subject to change without notice.
For complete details, please contact your local MONOCROM sales representative.

UNE EN ISO 9001:2015

MONOCROM S.L.

C/Vilanoveta 6
08800 Vilanova i la Geltrù (Barcelona)
Spain
T. +34 938 149 450
F. +34 938 143 767
E. sales@monocrom.com
www.monocrom.com