

Direct Diode

Monocrom @PULS Direct Diode

Features:

- Passively cooled pulsed direct beam
- Clamping™ Patented Technology (Solder free mounting of laser bars)
- Long lifetime
- High reliability
- Low thermal resistances
- Wide storage temperature - 40° C to + 85° C
- No SMILE effect

Suitable for:

- Gated imaging
- Illumination
- LIDAR

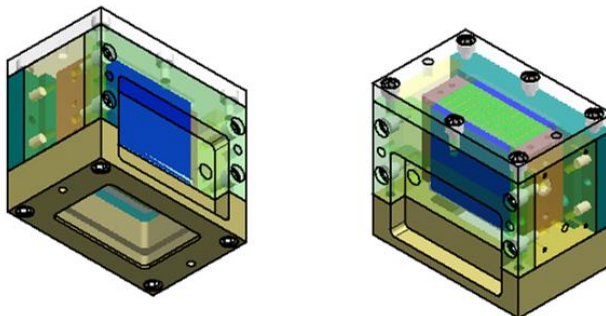
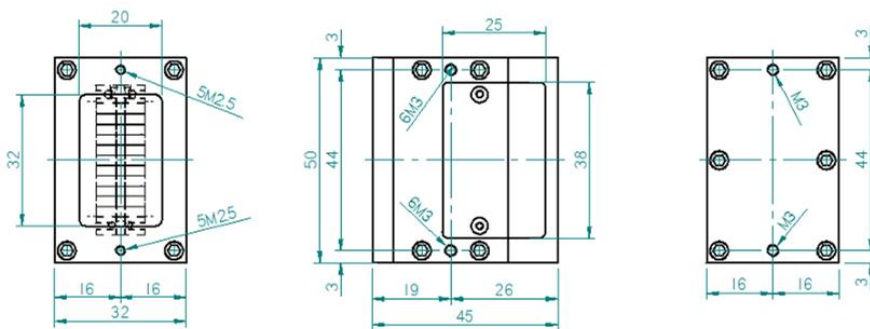

Monocrom@PULS Direct Diode

Product specification are subject to change without notice.
For complete details, please contact your local MONOCROM sales representative.

UNE EN ISO 9001:2015

MONOCROM S.L.

C/Vilanoveta 6
08800 Vilanova i la Geltrú (Barcelona)
Spain
T. +34 938 149 450
F. +34 938 143 767
E. sales@monocrom.com
www.monocrom.com

Monocrom @PULS Direct Diode I TECH SPECIFICATIONS

Laser Parameters ^(1,2,3,4)	
Wavelength ⁽⁵⁾ [nm]	760 - 2200
Wavelength tolerance [nm]	± 20
Peak power [W]	< 250 / laser bar
Operating current [A]	< 265
Voltage @ connectors ⁽⁶⁾ [V]	< 2 / laser bar
Pulse length [ns]	< 100
Repetition rate [Hz]	500
Number of laser bars	<10
Optical efficiency [%]	98 typ.
Laser bar smile [nm]	< 0.3
Optics	
Emission width [mm]	10
Emission height [mm]	7.5
Horizontal divergence ⁽⁷⁾ [°]	10
Vertical divergence ⁽⁷⁾ [°]	30
Optics available	FAC/SAC/BT
Body	
Cooling	TEC
Electrical connections	cathode M3 / anode M4
Weight [g]	250
Package dimensions (W x H x L) [mm]	See outline
Laser class product (EN-60825)	4
Expected lifetime	2 10 ⁹ pulses

Specifications at 20 °C, in the beginning of lifetime.

1. This is a preliminary specification sheet, validation of specification is in process.
2. If any other requirements are needed, please contact us.
3. Specifications at 20 °C, at the beginning of the lifetime.
4. Specification are subjected to chips availability.
5. Other wavelengths on request.
6. Voltage from the power supply must be higher, as due to high current there will be a voltage drop in the cables
7. Measured at FW95% energy.

Monocrom@PULS Direct Diode

Product specification are subject to change without notice.
For complete details, please contact your local MONOCROM sales representative.

UNE EN ISO 9001:2015

MONOCROM S.L.

C/Vilanoveta 6
08800 Vilanova i la Geltrú (Barcelona)
Spain
T. +34 938 149 450
F. +34 938 143 767
E. sales@monocrom.com
www.monocrom.com